

Kentech Instruments Ltd., Unit 9, Hall Farm Workshops, South Moreton, Didcot, Oxon, OX11 9AG, U.K.

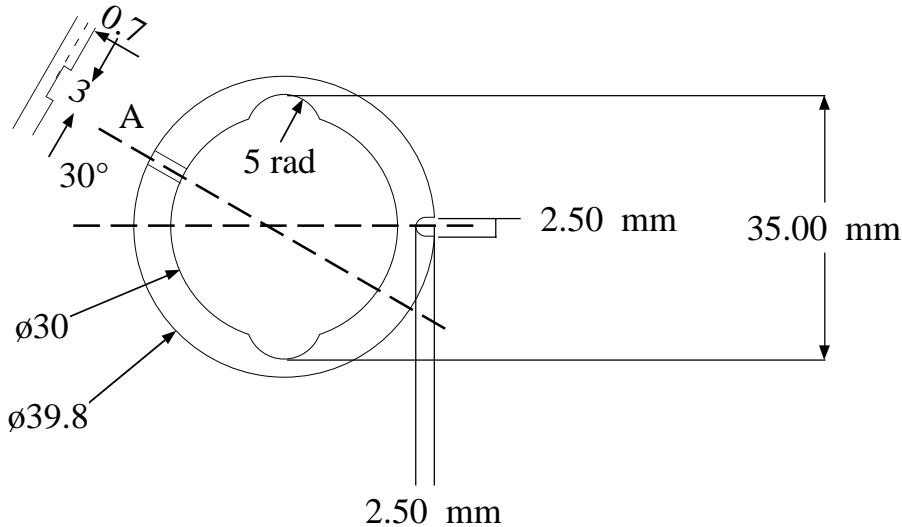

Thickness	Number
2mm	10
3mm	0
0.5mm	0

no cut at A

Material PTFE  
 Surface must be scrupulously clean, Preferably freshly machined with no ingrained oil or dirt at all.